

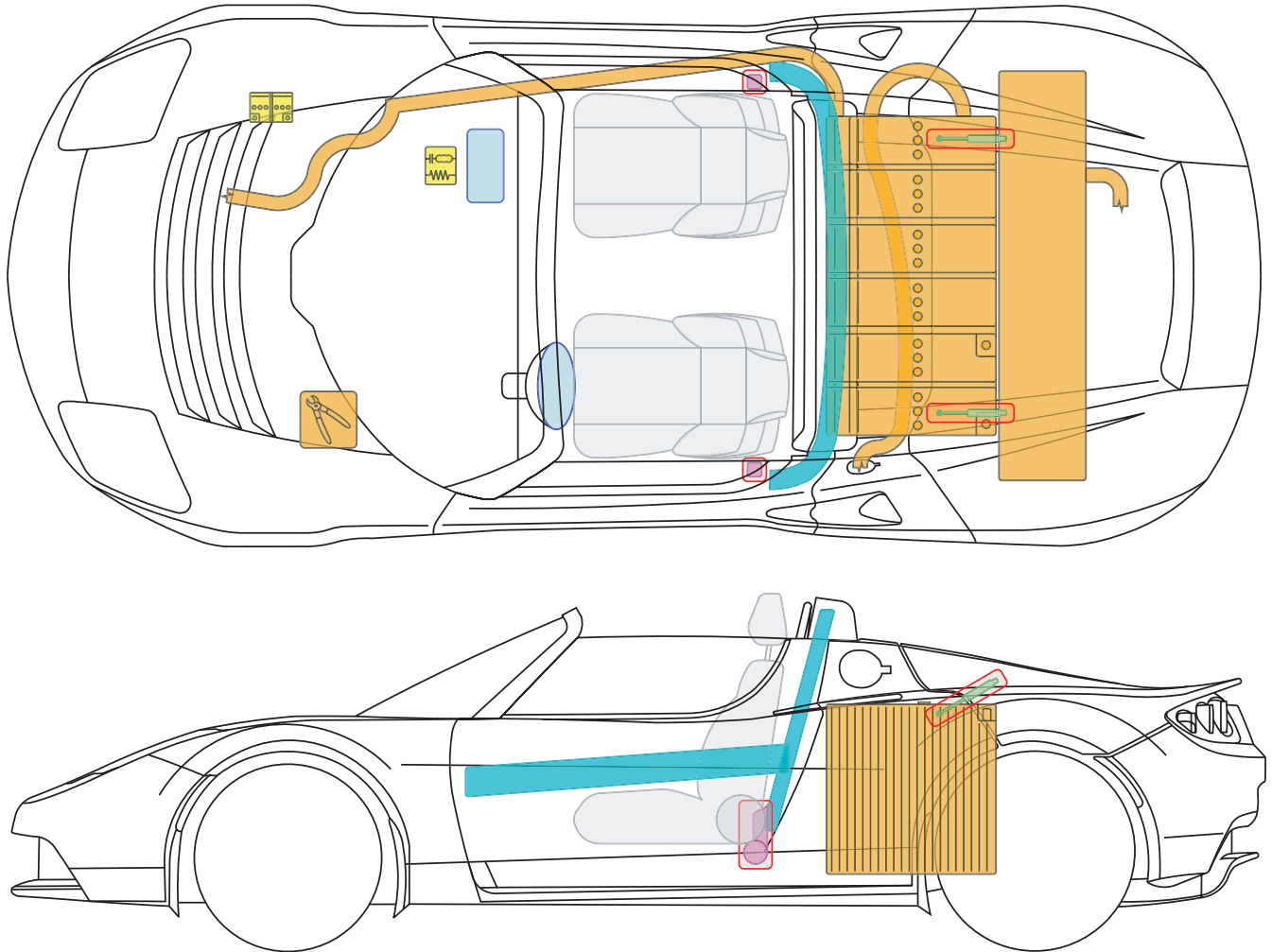

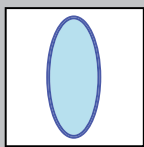

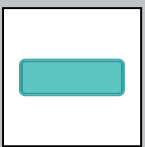

TESLA Roadster

(2010-2013 (Powertrain 2.0 and 2.5))

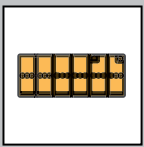
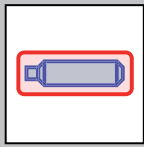
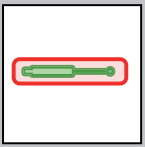
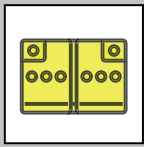

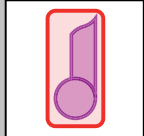
Legend

	Airbag		Reinforce- ment		SRS control unit		Lithium Ion (Li-Ion) battery pack
	Stored gas inflator		Pressurized gas cylinder		12V battery		High voltage power cable/ component
	Seat belt pre-tensioner				Emergency disconnect cable		

Roadster

TESLA

Roadster

(2010-2013 (Powertrain 2.0 and 2.5))



General instructions

- Always assume the vehicle is powered, even if it is silent!
- Never touch, cut, or open any orange high voltage power cable or high voltage component!
- Do not damage the battery pack, even if the propulsion system is deactivated.
- The battery pack has an inertia switch that is designed to activate in a collision, which disables the high voltage system.
- **Caution! After deactivation, the high voltage circuit requires 5 minutes to deplete.**
- **Caution! The SRS control unit is equipped with a backup power supply with a discharge time of approx. 30 sec.**

Immobilize the vehicle

1. Chock wheels.
2. Set parking brake.
3. Select the Park button on the gear switch.



Deactivate the vehicle

1. Turn the ignition key to the "OFF" position and remove it.
2. Open the hood by pulling the release handle to the left of the steering column.
3. Locate the cut loop at the base of the windshield, near the brake fluid reservoir.
4. Double cut a section out of the loop so that the ends cannot reconnect.

