



2010
FUSION HYBRID
MILAN HYBRID

EMERGENCY RESPONSE GUIDE



FOREWORD

The emergency response procedures for the Fusion Hybrid and Milan Hybrid vehicles are similar to those for traditional gasoline-powered vehicles with the addition of special considerations for the high-voltage electric system components.

The Fusion Hybrid or Milan Hybrid vehicles use a conventional gasoline engine in addition to an electric motor to power the vehicle. The energy used to power the vehicle comes from gasoline (used by the internal combustion engine) and electricity (used by the electric motor).

- Gasoline is stored in a traditional fuel tank.
- Electricity is stored in a high-voltage battery pack.

The combination of a gasoline engine and electric motor provides for improved performance (V6 performance with a 4-cylinder engine and electric motor), reduced emissions and improved fuel economy. The high-voltage system is self contained, never needing to be plugged into an electrical outlet for recharging. The system incorporates a generator that recharges the high-voltage batteries during cruising and braking from the engine.

The information in this guide will allow response to emergencies involving Fusion Hybrid or Milan Hybrid vehicles to be as safe as with conventional vehicles.

The Fusion Hybrid and Milan Hybrid vehicles have been designed with many safety features for your protection. These features help provide safe access to the vehicle under various conditions. However, when approaching a high-voltage vehicle in a fire, rescue or recovery situation, always follow one industry standard rule:

***ALWAYS ASSUME THE VEHICLE'S
HIGH-VOLTAGE SYSTEM IS POWERED UP !***

FUSION HYBRID AND MILAN HYBRID VEHICLE IDENTIFICATION

- The Fusion Hybrid and Milan Hybrid vehicles can be easily identified by the Ford “green leaf highway” badges located on the left and right front doors. There is a “Hybrid” nameplate on the trunk lid that also includes the “green leaf highway” icon.

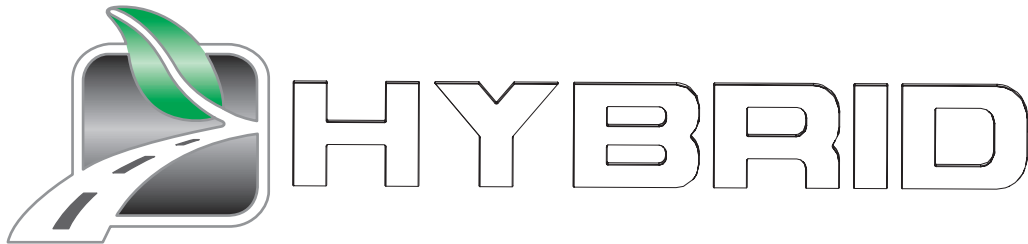

Hybrid Nameplate
with “Green Leaf
Highway” Badge on
Front Door

Unique Hybrid
Specific Wheels

- The Fusion Hybrid and Milan Hybrid vehicles have a unique engine appearance cover with a raised “green leaf highway” icon and HYBRID lettering.

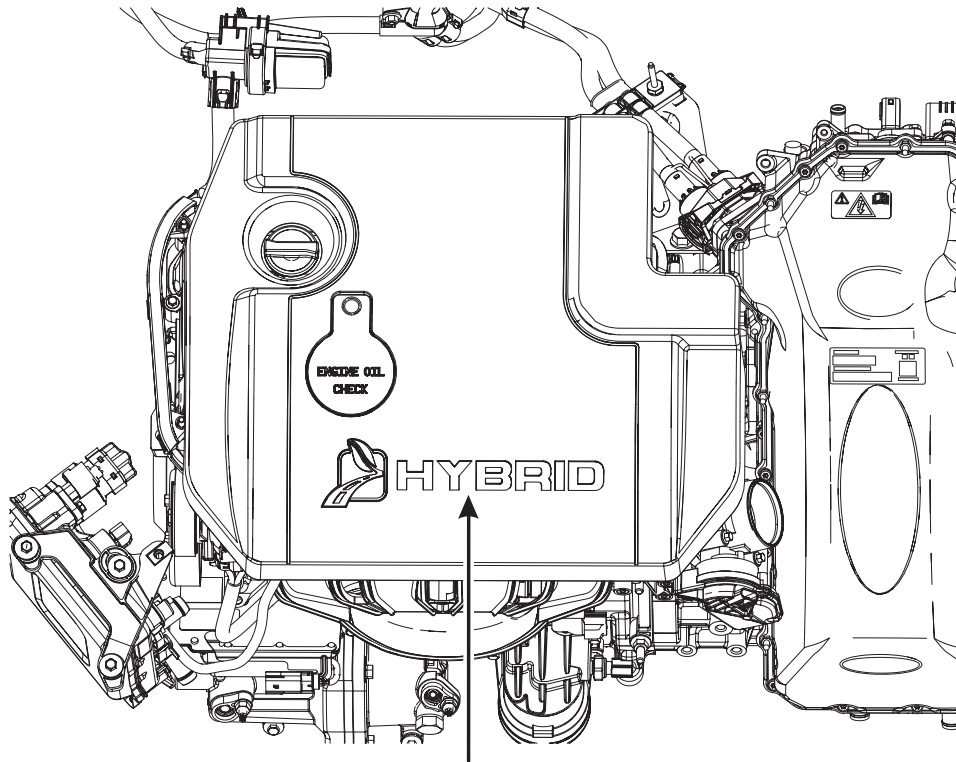

Unique Hybrid Engine Appearance Cover with “Green Leaf Highway” Icon

- The 5th, 6th and 7th digits of the Vehicle Identification Number (VIN) identify the Hybrid vehicle line.

VIN POSITIONS 5, 6 and 7	VEHICLE
P0L	Fusion Hybrid — Front Wheel Drive (FWD)
M0L	Milan Hybrid — Front Wheel Drive (FWD)

SAMPLE VIN

3 F A D P 0 L 3 0 A R 1 0 0 0 0 1



Fusion Hybrid FWD

HIGH-VOLTAGE ELECTRICAL DISCONNECT FEATURES

The following list describes certain features that have been incorporated into the Hybrid vehicles that allow for either simple or automatic shutoff of the high-voltage electrical systems.

- High-Voltage Fuse — In the event of a high-current short circuit, the high-voltage fuse will open, disabling the high-voltage system.
- High-Voltage Interlock Circuit — Whenever a high-voltage connector is disconnected, the high-voltage interlock circuit opens and disables the high-voltage system.
- Ignition Key in OFF Position — Any time the ignition lock cylinder is in the OFF position, the high-voltage system is disabled.
- High-Voltage Service Disconnect — Whenever the high-voltage service disconnect (located behind the rear seat) is removed, the high-voltage system is disabled. For additional information, refer to Page 9 in this manual.
- Thermal Sensors — In the event the ignition key is left in the ON position and the high-voltage battery temperature exceeds 60°C (140°F), thermal sensors located near the high-voltage battery will automatically disable the high-voltage battery.

HIGH-VOLTAGE WARNING DECALS

- Warning decals, as shown here, will be located on components included in the high-voltage system.

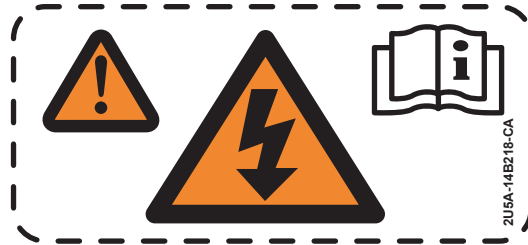

⚠ WARNING: HIGH VOLTAGE VEHICLE ⚠	
TO REDUCE THE RISK OF POSSIBLE SERIOUS INJURY (SHOCK OR BURN) OR DEATH: COMPONENTS MARKED WITH THE HIGH VOLTAGE SYMBOL ⚡ CONTAIN HIGH VOLTAGE AND HIGH TEMPERATURES AND SHOULD BE AVOIDED. SERVICE MUST BE PERFORMED BY QUALIFIED PERSONNEL ONLY. 📖	
⚠ AVERTISSEMENT : CIRCUITS HAUTE TENSION DU VÉHICULE ⚠	
POUR RÉDUIRE LES RISQUES DE BLESSURES GRAVES (CHOCS OU BRÛLURES) OU MORTELLES : LES ÉLÉMENTS ACCOMPAGNÉS DU SYMBOLE HAUTE TENSION ⚡ ONT UNE TENSION ET DES TEMPÉRATURES ÉLEVÉES ET DOIVENT ÊTRE ÉVITÉS. 📖	
LA RÉPARATION ET L'ENTRETIEN DOIVENT ÊTRE EFFECTUÉS PAR UN TECHNICIEN QUALIFIÉ SEULEMENT.	4L8A-14B218-AB

HYBRID COMPONENT LOCATION AND IDENTIFICATION

This chart provides the location, description and basic function of the hybrid system components. Refer to the hybrid component description on the following page.

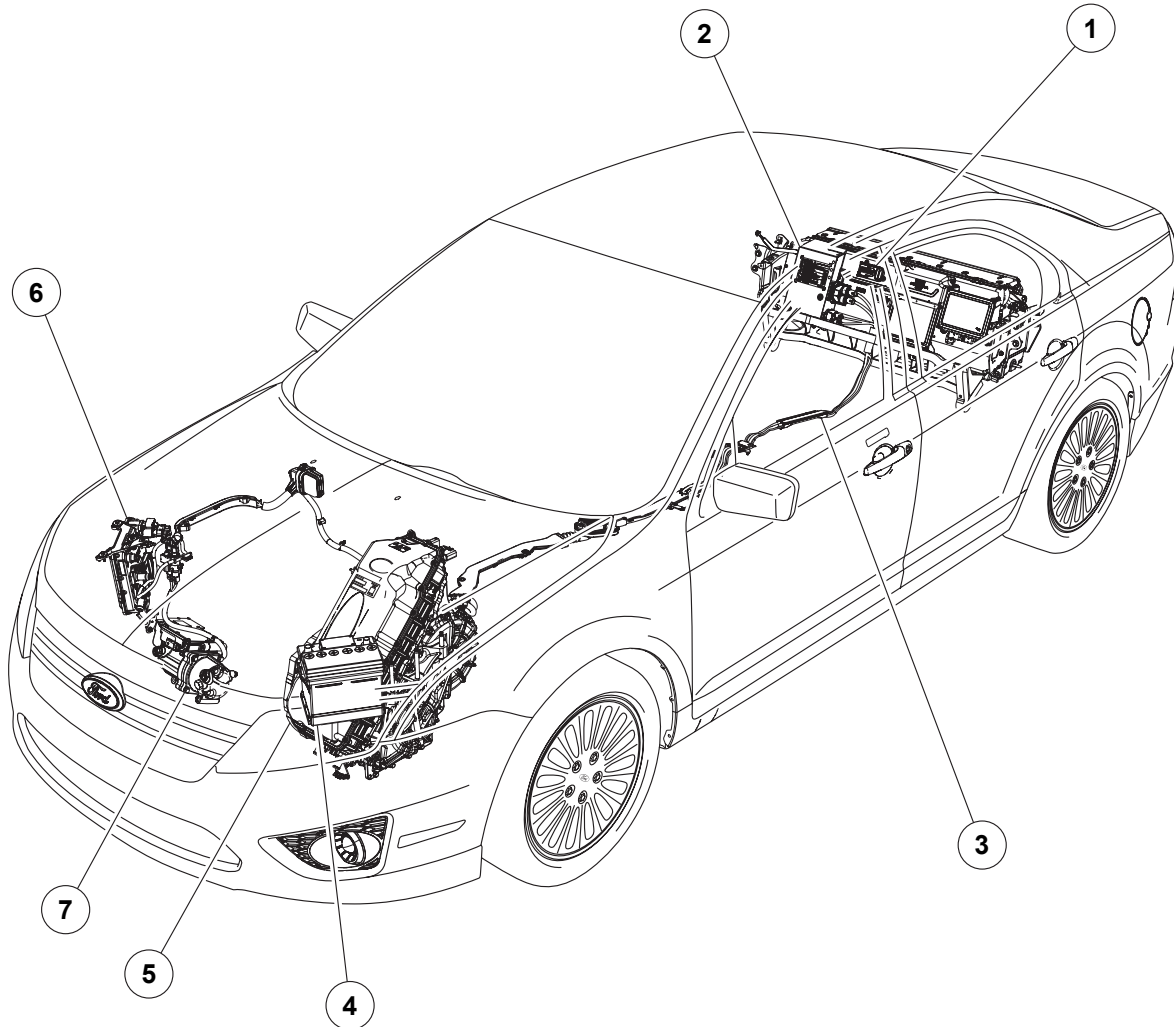

NOTE: All high-voltage wires and harnesses are wrapped in orange-colored insulation.

	COMPONENT	LOCATION / DESCRIPTION	FUNCTION
1	High-Voltage Service Disconnect	<ul style="list-style-type: none"> • Orange rectangle with a molded plastic handle, about 100 mm (4 in) in length. 	Provides means to disconnect high-voltage battery for safely servicing vehicle.
2	High-Voltage Battery 275 Volts	<ul style="list-style-type: none"> • Located behind the rear seatback. • Sealed nickel-metal hydride. 	Provides high-voltage storage (275 V) for vehicle propulsion requirements.
3	High-Voltage Wiring	<ul style="list-style-type: none"> • Runs along the vehicle's floorpan from the high-voltage battery to the Electronically Controlled Continuously Variable Transaxle (eCVT), to DC-to-DC converter, then the electric A/C unit. • All high-voltage wiring has orange-colored insulation. 	Provides physical path for high-voltage circuitry.
4	12-Volt Battery	<ul style="list-style-type: none"> • Located under the hood on driver side of the vehicle. • Typical automotive 6-cell lead/acid design. 	Provides 12-volt power for vehicle accessories.
5	Electronically Controlled Continuously Variable Transaxle (eCVT)	<ul style="list-style-type: none"> • Transverse-mounted design similar to the non-Hybrid Fusion/Milan vehicles. • Contains the traction motor, generator motor and hybrid electronics. 	Provides delivery of power to wheels for vehicle propulsion, generates electricity to re-charge the batteries during operation and contains certain hybrid electronics.
6	DC/DC Converter	<ul style="list-style-type: none"> • Located under the hood on the passenger side forward of the strut tower. 	Provides 12 volts of power to charge the 12-volt battery and run vehicle accessories.
7	Electric A/C Compressor	<ul style="list-style-type: none"> • Located in the front of the engine. 	Provides electric A/C operation. Replaces the belt driven A/C compressor.

HIGH-VOLTAGE SERVICE DISCONNECT

To gain access to the high-voltage service disconnect, the rear seat must be lowered. The rear seat is released from the trunk area.

- Locate the seat backrest latch release levers (2) between the high-voltage battery and the body sheet metal.
- Push the release lever toward the outboard side of the vehicle.

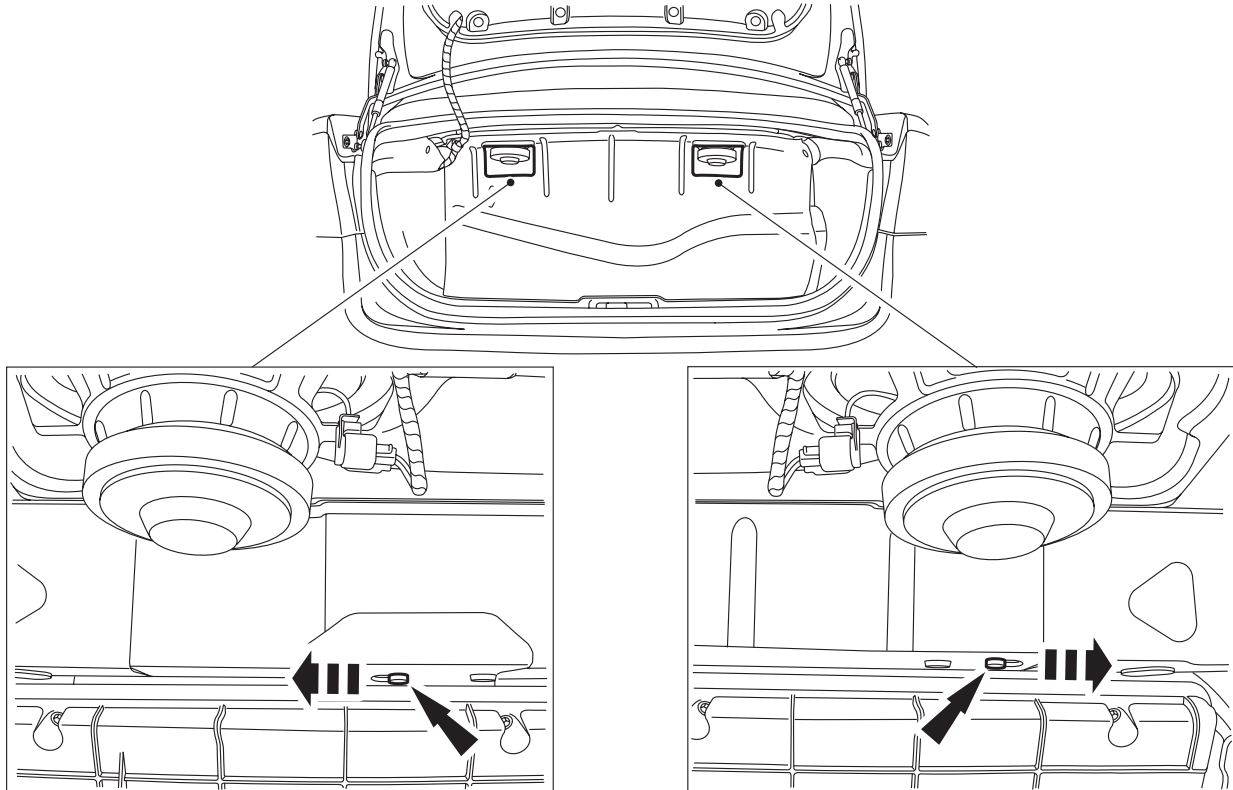

HIGH-VOLTAGE BATTERY PACK

WARNING

- Removing the high-voltage service disconnect will disconnect the high-voltage from the vehicle.
- The individual cells inside the battery pack will still be charged.
- Do not cut, weld or screw into the high-voltage battery case or penetrate the batteries in any way.

The high-voltage battery pack is located behind the rear seatback.

- The total voltage of the battery pack is approximately 275 volts DC.
- The battery case is designed to be water resistant.
- The battery cells contain a base electrolyte (consisting of potassium hydroxide as the dominant active ingredient) that is absorbed in a special paper. The electrolyte will not leak from the battery under most conditions, however, if the battery is crushed, it is possible for a small amount (drops) of electrolyte to leak.

These warnings must be observed when working with a damaged battery:

NOTE: If possible, remove the high-voltage service disconnect.



1. Exposure to electrolyte could cause skin/eye irritation and/or burns. If exposed, rinse with large amounts of water until the soapy feel is gone. Personal Protective Equipment (PPE) such as splash shield or safety goggles, gloves (latex, rubber or Nitrile), an apron or overcoat suitable to protect against alkaline and rubber boots are required when handling damaged batteries. Fold-down helmet shields are not acceptable for acid or alkaline spills.
2. If the battery is exposed to intense heat, it is possible that hydrogen could be released from the battery. Appropriate precautions should be taken to make sure the area is properly ventilated, such as, opening the vehicle windows or doors.

APPROACHING A DAMAGED HIGH-VOLTAGE VEHICLE

1. FOLLOW EXISTING TRAINING AND INCIDENT COMMANDER DIRECTION.

- This guide provides only supplemental information as it pertains to the Fusion Hybrid and Milan Hybrid vehicles. The same rules apply when approaching any potential high-voltage situation. Always follow your high-voltage safety training. Some precautions to be taken in any high-voltage situation include:
 - Remove all jewelry (watches, necklaces and earrings). Metal objects are conductors of electricity.
 - Wear the necessary PPEs (high-voltage rubber gloves, face shield, insulated boots, protective raincoat or apron).
 - Bring the following equipment:
- Class ABC powder-type fire extinguisher
- A non-conductive object – about 1.5 m (5 ft) long – used to safely push someone away from the vehicle if they accidentally come in contact with high-voltage.

2. APPROACHING A DAMAGED VEHICLE.

- Disable the high-voltage electrical system using as many of the following steps as possible:
 - Secure the vehicle — place the shift lever into the PARK position. Remove the ignition key. Block the wheels, if necessary. Removing the ignition key or turning the key to the OFF position will disconnect the high-voltage system.
 - Disconnect the negative cable from the 12-volt battery – this will also disable the high-voltage system.
 - If possible, remove the high-voltage service disconnect (See Page 9).

SPECIAL NOTES

- If the vehicle is on fire, use a Class ABC powder-type extinguisher to contain and smother the flames. If water is being used, large amounts of water will be required (e.g., from a fire hydrant) to extinguish the flames.
- If the vehicle has any exposed cables, make sure to wear high-voltage rubber gloves and other protective clothing. Do not touch any broken or damaged high-voltage orange cables. Treat severed cables as if they contain high voltage.
- If the vehicle is submerged in water, do not touch any high-voltage components or orange cables while extricating the occupant(s). Do not remove the vehicle until you are sure the high-voltage battery is completely discharged. A submerged high-voltage battery may produce a fizzing or bubbling reaction. The high-voltage battery will be discharged when the fizzing or bubbling has completely stopped.

3. IF THE HIGH-VOLTAGE BATTERY CASE HAS BEEN RUPTURED.

- Just like any other battery, hose the area down with large amounts of water.

4. MOVING DAMAGED VEHICLES — WRECKER DRIVERS.

- Turn the vehicle ignition key to the ACCESSORY position to release the locking steering wheel.
- If possible, remove the high-voltage service disconnect.
- Follow the guidelines in the Wrecker Towing Manual.
 - Front Tow: Wheel Lift (FWD)
 - Rear Tow: Wheel Lift with Dolly (FWD)
 - Flat bed: Front and Rear

5. SPECIAL NOTE TO SALVAGE YARDS.

- If a vehicle with a high-voltage battery is to be scrapped, the high-voltage battery must be disposed of following all local, state/provincial and federal guidelines.