

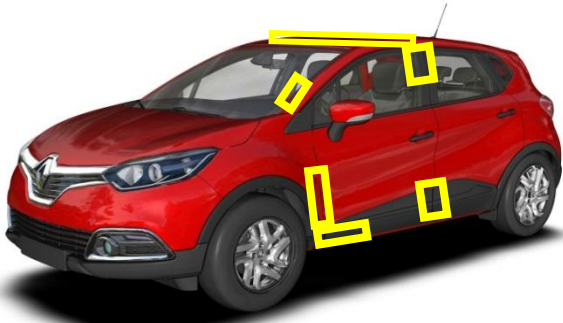

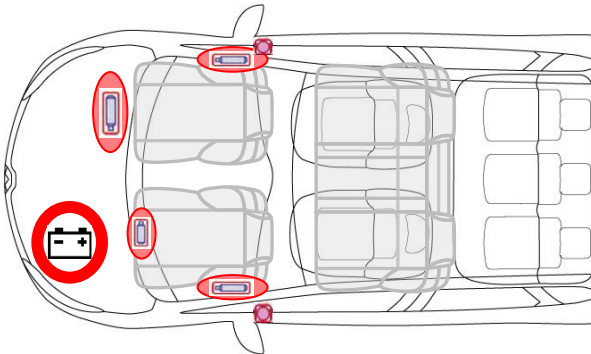







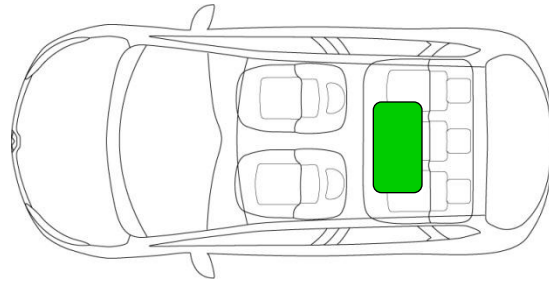



Renault Captur

| | Énergie principale | Stop & Start | Hybridé électrique |
|------------|--------------------|--------------|--------------------|
| Diesel | | | |
| Essence | | | |
| Électrique | | | |

Légende

| | | | | | | | |
|--|---|---|--|---|-------------------------------|---|--|
|  | Zone déconseillée |  | Cartouches pyrotechniques |  | Réservoir de carburant |  | Circuit Haute Tension |
|  | Zone dangereuse |  | Airbag |  | Batterie Basse Tension annexe |  | Service Plug (coupure circuit Haute Tension) |
|  | Couleur hachure = Danger spécifique à une énergie (cf. tableau ci-dessus) |  | Batterie Basse Tension alimentant la pyrotechnie | | |  | Batterie Haute Tension |



Commentaires

- ✓ Véhicule 5 places
- ✓ Air bags tête-thorax dans les sièges avant (voir photo ci-dessus)
- ✓ Système Stop and start sans danger pour l'intervention
- ✓ Plaque de renfort centrale sous la planche de bord (voir photo ci-dessus)
- ✓ Commande d'ouverture du capot coté conducteur en bas à gauche

| Marque | Modèle | Silhouette(s) | Année de lancement | Référence interne | Date création | Date mise à jour | N° de version |
|---------|--------|---------------|--------------------|-------------------------|---------------|------------------|---------------|
| Renault | CAPTUR | Phase 1 | 2013 | RSE-FAD-J87-ph1-2013-v1 | 10/07/2013 | | V1.0 |