

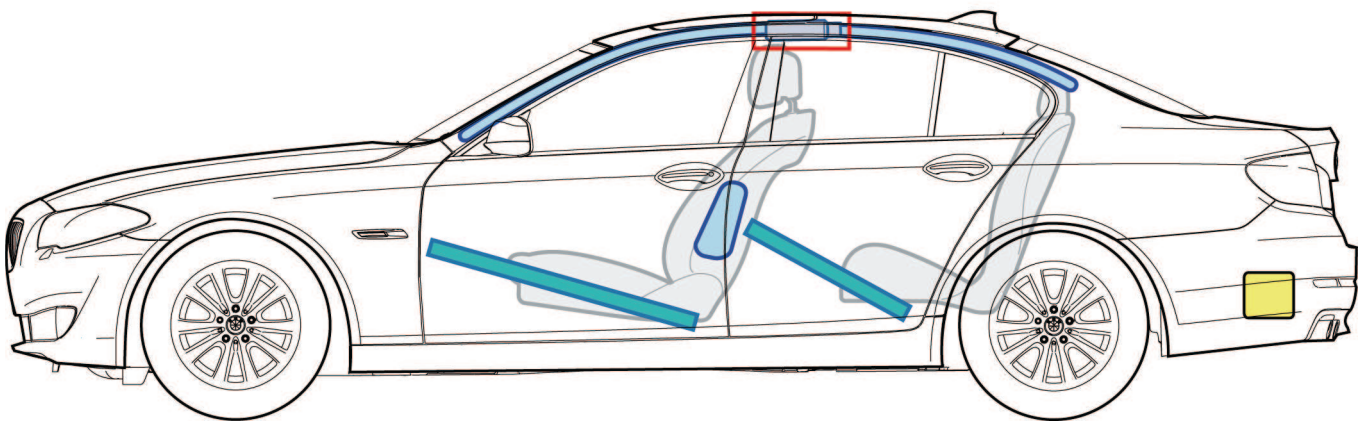

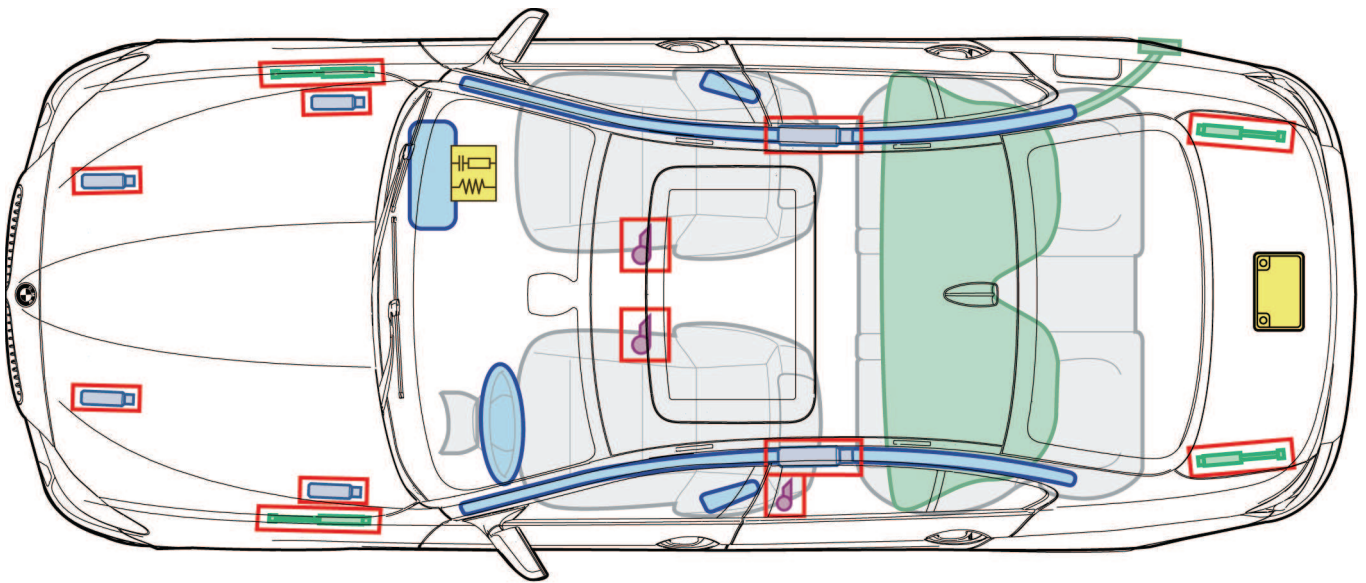







# Série 5 F10

(depuis 03/2010)

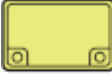

## Légende

	Airbags		Renfort de carrosserie		Boîtier électronique airbag
	Générateur de gaz		Amortisseur à gaz		Batterie de 12 V
	Rétracteur de ceinture		Réservoir de carburant		

Ce récapitulatif montre l'équipement maximal du véhicule.